

AGRICULTURAL MACHINERY

sitrex®
Spa

SPARE PARTS LIST

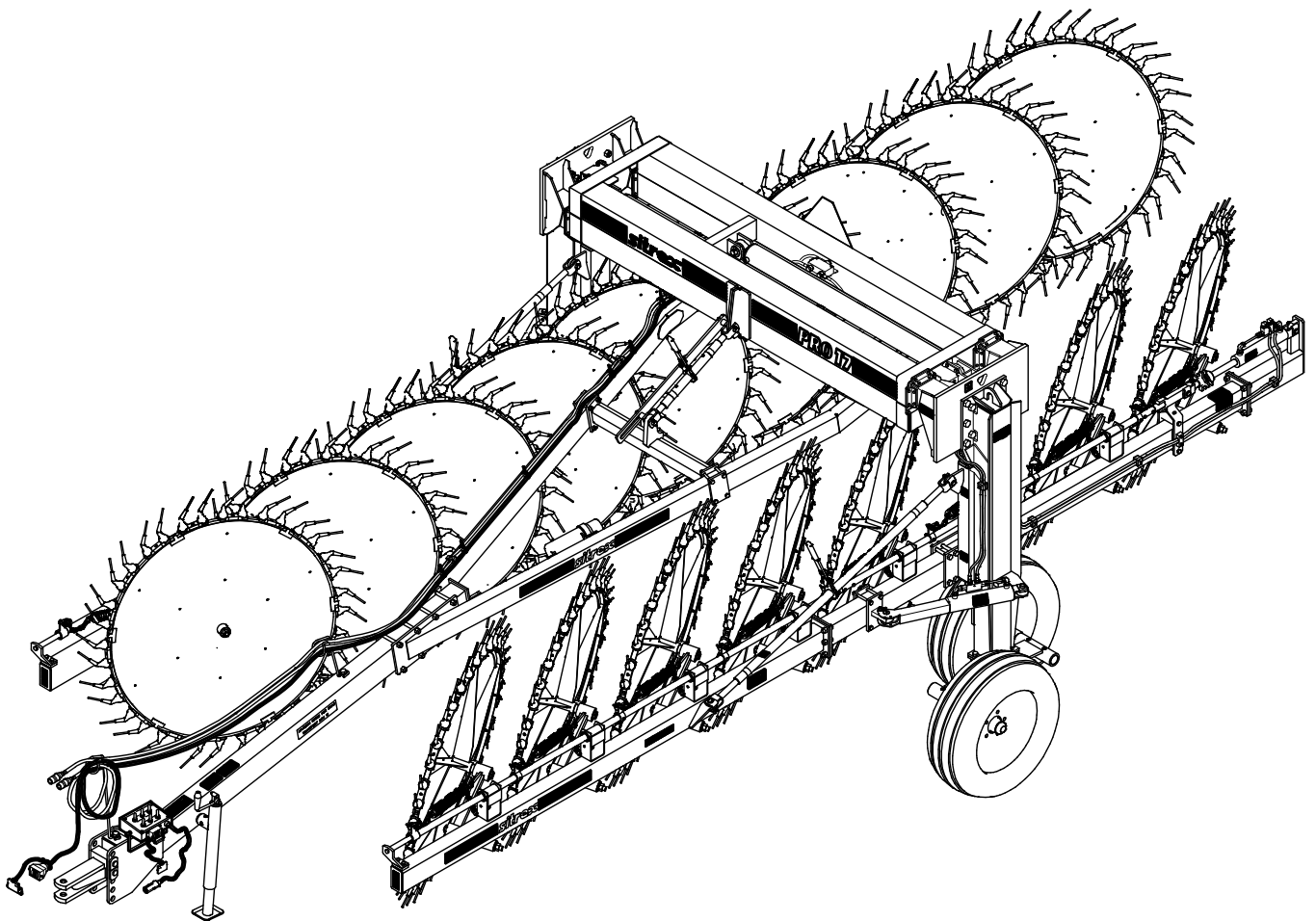

PRO SERIES 17 WHEELS

05-2014 (FROM SERIAL NUMBER 247731)

TABLE PART NO 920.294/a

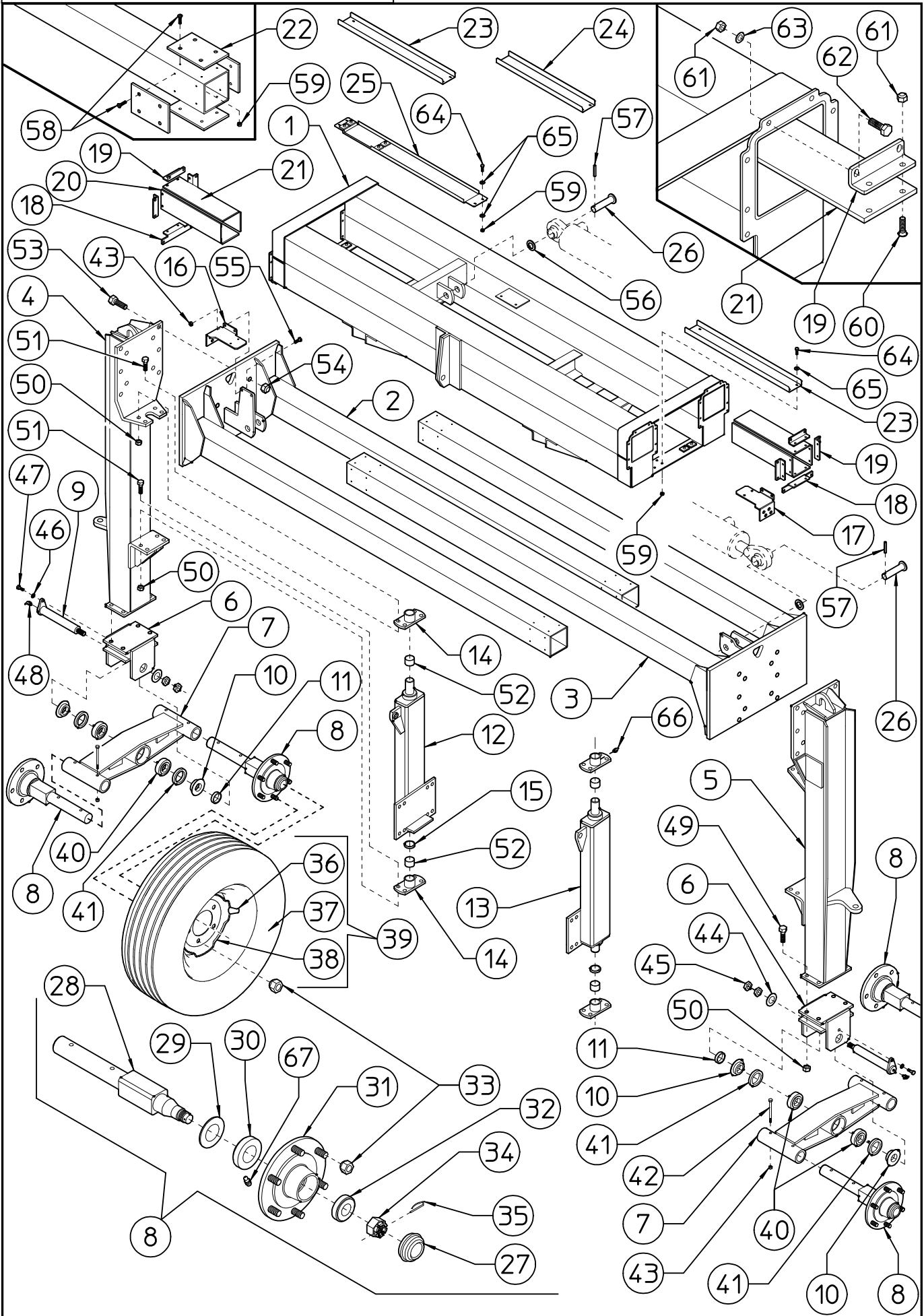

TABLE PART NO 920.294/a

ITEM	Q.ty	PART NO	DESCRIPTION	NOTE
1	1	230.527	CROSSPIECE	
2	1	230.528	RH CROSSPIECE	
3	1	230.529	LH CROSSPIECE	
4	1	230.530	RH WHEEL SUPPORT	
5	1	230.531	LH WHEEL SUPPORT	
6	2	230.556	SUPPORT	
7	2	230.557	SUPPORT	
8	4	230.554	HUB ASSY	
9	2	230.603	PIN ø45	
10	4	230.560	BUSH	
11	2	230.561	SHIM	
12	1	230.975	RH SUPPORT (FROM SERIAL NO.238437)	
13	1	230.976	LH SUPPORT (FROM SERIAL NO.238437)	
14	4	230.562	SUPPORT	
15	2	230.575	SHIM	
16	1	230.748	RH HOSE SUPPORT	
17	1	230.749	LH HOSE SUPPORT	
18	4	230.537	SUPPORT	
19	12	230.536	SUPPORT	
20	2	230.622	SLIDING	
21	14	230.538	SLIDING	
22	16	230.539	SLIDING	
23	2	230.534	SUPPORT	
24	2	230.619	SUPPORT	
25	1	230.535	SUPPORT	
26	4	230.604	PIN ø30	
27	4	630.449	CAP	
28	4	230.555	PIN	
29	4	630.446	DUST COVER	
30	4	630.445	BEARING 30210	
31	4	230.558	HUB	
32	4	630.444	BEARING 30207	
33	24	620.300	NUT M18x1,5	
34	4	630.447	NUT M30x1,5 UNI 5594	
35	4	600.291	SPLIT PIN ø3	
36	4	630.590	VALVE	
37	4	630.588	TIRE 10.0/75-15.3	
38	4	630.589	RIM 15NB01A	
39	4	630.587	COMPLETE WHEEL 10.5 - 15.3 - 10	
40	4	630.450	BEARING 30209A	
41	4	620.951	SEAL ø55-85x10	
42	8	630.485	SCREW M10x70 DIN 912	
43	12	600.029	NUT M10 DIN 980	
44	2	610.522	WASHER ø34-60x5 DIN 125A	
45	4	610.933	NUT M33 DIN 936	
46	2	600.089	WASHER ø13 DIN 125A	
47	2	600.770	SCREW M12x20 DIN 933	
48	2	610.808	GREASE NIPPLE M8-90°	
49	8	610.167	SCREW M16x45 DIN 933	
50	24	600.080	NUT M16 DIN 980	
51	16	600.384	SCREW M16x50 DIN 933	
52	4	630.451	BUSH ø40-44x30	
53	20	600.251	SCREW M20x60 DIN 931	
54	20	600.717	NUT M20 DIN 980	
55	4	600.148	SCREW M10x30 DIN 933	
56	4	600.587	WASHER ø31-56x4 DIN 125A	
57	4	600.586	SPRING PIN ø10x60 DIN 1481	
58	64	630.483	SCREW M6x20 similar to DIN 7991	
59	80	600.472	NUT M6 DIN 980	
60	32	630.136	SCREW M8x25 similar to DIN 7991	
61	64	600.076	NUT M8 DIN 980	
62	32	600.702	SCREW M8x25 DIN 933	
63	32	600.115	WASHER ø8,4 DIN 125A	
64	16	630.003	SCREW M6x20 DIN 933	
65	28	600.135	WASHER ø6,6-18x2 UNI 6593	
66	4	600.124	GREASE NIPPLE M6	
67	2	600.034	GREASE NIPPLE M8	

TABLE PART NO 920.295/a

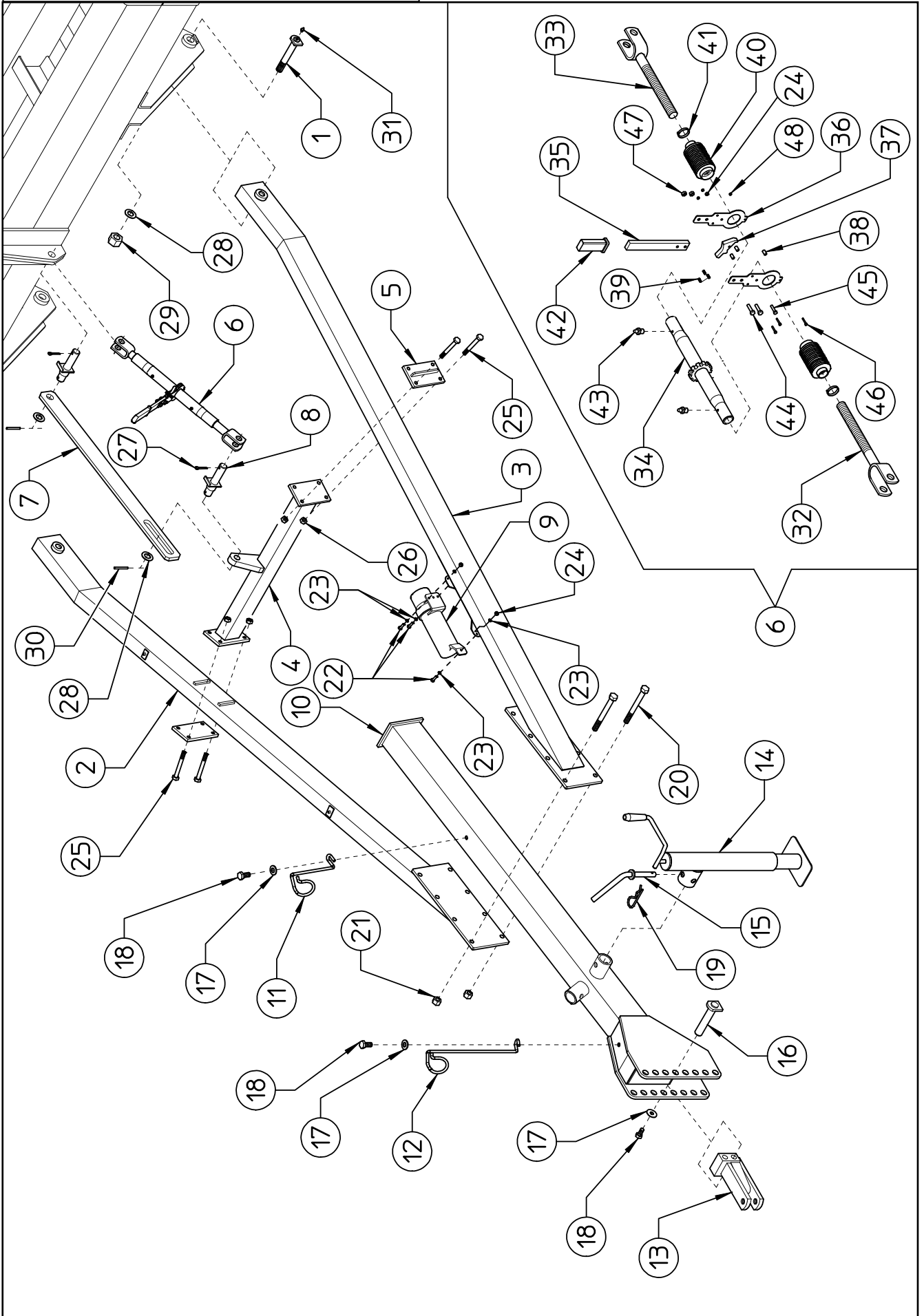

TABLE PART NO 920.295/a

ITEM	PART NO	Q.ty	DESCRIPTION	NOTE
1	230.605	2	PIN ø30	
2	230.601	1	RH DRAWBAR	
3	230.602	1	LH DRAWBAR	
4	250.012	1	SUPPORT	
5	250.013	2	COUNTERPLATE	
6	230.628	1	RATCHET LINK	
7	230.608	1	TIE ROD	
8	230.606	2	PIN ø25	
9	230.457	1	CANISTER	
10	230.566	1	FRONT DRAWBAR	
11	230.573	1	REAR HOSE SUPPORT	
12	230.574	1	FRONT HOSE SUPPORT	
13	210.306	1	TRACTOR HITCH	
14	220.166	1	PARKING STAND	
15	200.222	1	PIN	
16	200.828	2	PIN ø25	
17	500.160	4	WASHER ø12-40x4	
18	600.441	4	SCREW M12x25 DIN 933	
19	600.019	1	SPLIT PIN ø3	
20	620.866	8	SCREW M16x145 DIN 931	
21	600.080	8	NUT M16 DIN 980	
22	630.003	3	SCREW M6x20 DIN 933	
23	600.135	6	WASHER ø6,6-18x2 UNI 6593	
24	600.472	4	NUT M6 DIN 980	
25	600.003	8	SCREW M14x100 DIN 931	
26	600.075	8	NUT M14 DIN 980	
27	600.038	2	SPLIT PIN ø6x35 DIN 94	
28	600.336	4	WASHER ø25 DIN 125A	
29	620.255	2	NUT M24 DIN 980	
30	600.108	2	SPRING PIN ø8x40 DIN 1481	
31	600.034	2	GREASE NIPPLE M8	
32	220.219	1	RH TIEROD	
33	220.220	1	LH TIEROD	
34	220.218	1	TIE ROD	
35	220.213	1	LEVER	
36	220.205	2	SUPPORT	
37	220.070	1	HOOK	
38	220.215	3	SPACER	
39	220.073	1	SPRING	
40	220.192	2	RUBBER PROTECTION	
41	610.507	2	CLAMP ø25-40x9	
42	610.811	1	HANDLE	
43	600.124	2	GREASE NIPPLE M6	
44	600.702	2	SCREW M8x25 DIN 933	
45	600.202	1	SCREW M6x25 DIN 933	
46	610.717	3	SCREW M4x25 DIN 933	
47	600.076	2	NUT M8 DIN 980	
48	610.718	3	NUT M4 DIN 982	

TABLE PART NO 920.336

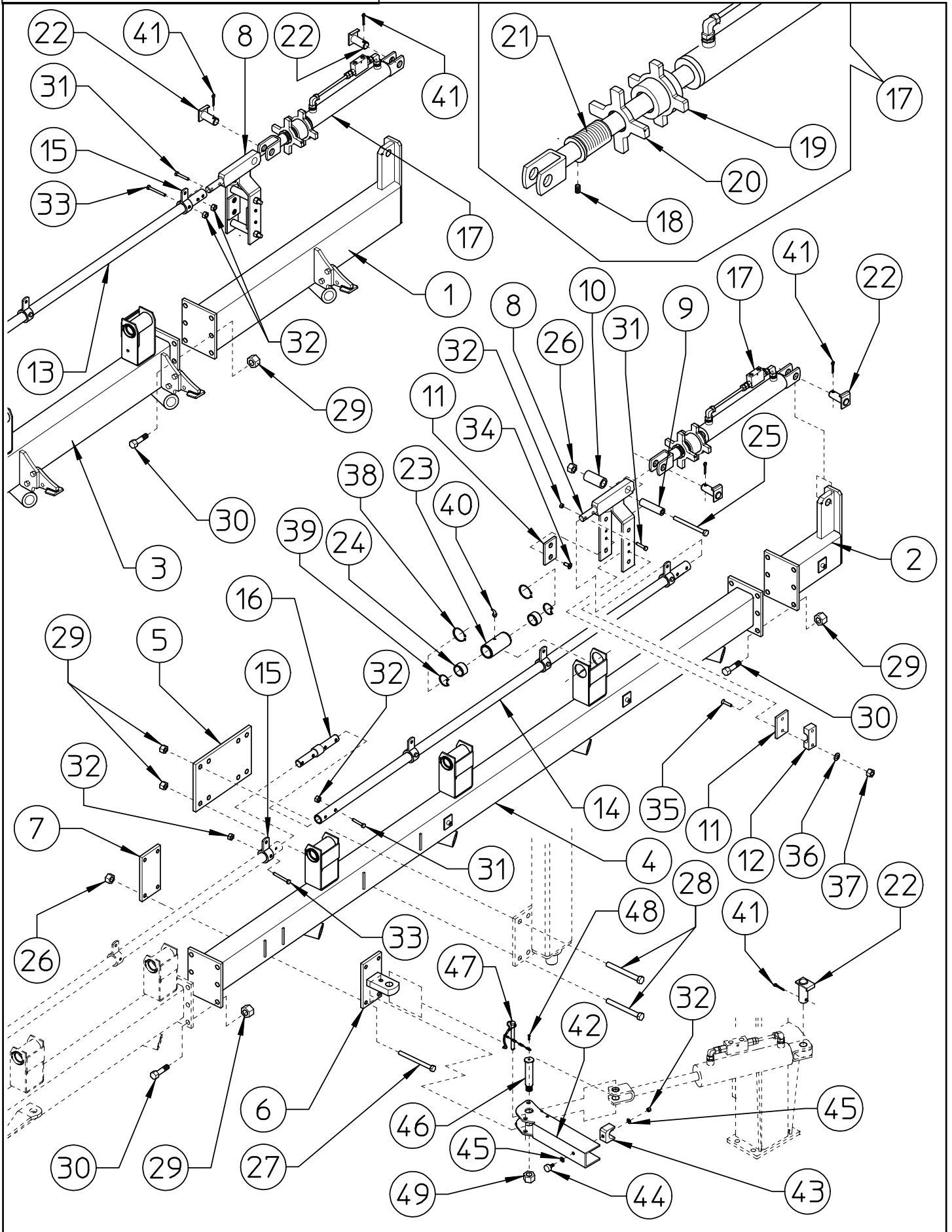

TABLE PART NO 920.336				
ITEM	PART NO	Q.ty	DESCRIPTION	NOTE
1	250.020	1	RH SUPPORT	With block
2	230.572	1	LH SUPPORT	
3	250.021	1	RH SECTION	With block
4	250.022	1	LH SECTION	With block
5	230.977	2	COUNTERPLATE (FROM SERIAL NO.238437)	
6	230.578	2	SUPPORT	
7	230.579	2	COUNTERPLATE	
8	230.585	2	SUPPORT	
9	230.607	4	SPACER	
10	230.613	2	BUSH	
11	210.858	4	SLIDING	
12	230.623	2	HOSE SUPPORT	
13	230.588	1	RH PIPE (L.2960-116,54")	
14	230.589	1	LH PIPE (L.2220-87,4")	
15	230.592	9	BUSH	
16	230.586	2	PIN ø22-35	
17	230.794	2	CYLINDER WITH BUSHING AND VALVE	
18	600.583	2	SCREW M6x10 DIN 914	
19	230.583	2	BUSH M40x1,5	
20	230.582	2	LOCK M40x1,5	
21	230.581	2	SCREW M40x1,5	
22	230.368	6	PIN ø25	
23	220.343	7	BUSH	
24	220.342	14	NYLON BUSH	
25	600.001	4	SCREW M12x140 DIN 931	
26	600.077	12	NUT M12 DIN 980	
27	600.225	8	SCREW M12x120 DIN 931	
28	610.698	16	SCREW M16x130 DIN 931	
29	600.080	40	NUT M16 DIN 980	
30	610.167	24	SCREW M16x45 DIN 933	
31	600.551	10	SCREW M8x45 DIN 931	
32	600.076	21	NUT M8 DIN 980	
33	610.525	9	SCREW M8x60 DIN 931	
34	610.663	4	SCREW M8x16 similar to DIN 7991	
35	630.489	4	SCREW M8x45 similar to DIN 7991	
36	600.229	4	SPRING WASHER ø8,4 DIN 125A	
37	600.037	4	NUT M8 DIN 934	
38	610.833	14	SNAP RING E50 DIN 471	
39	610.898	14	RING SB 44	
40	600.968	7	GREASE NIPPLE M6-45°	
41	600.038	6	SPLIT PIN ø6x35 DIN 94	
42	230.763	2	LOCK	
43	230.764	2	RUBBER LOCK	
44	630.534	2	SHOCK ABSORBER ø30x15-M8x20	
45	600.115	4	WASHER ø8,4 DIN 125A	
46	230.765	2	PIN ø25	
47	230.766	2	SPLIT PIN ø10 WITH CHAINE	
48	600.668	2	SCREW M6x12 DIN 931	
49	600.717	2	NUT M20 DIN 980	
*	230.767	2	PIN ø25 WITH ACCESSORIES	

TABLE PART NO 920.335

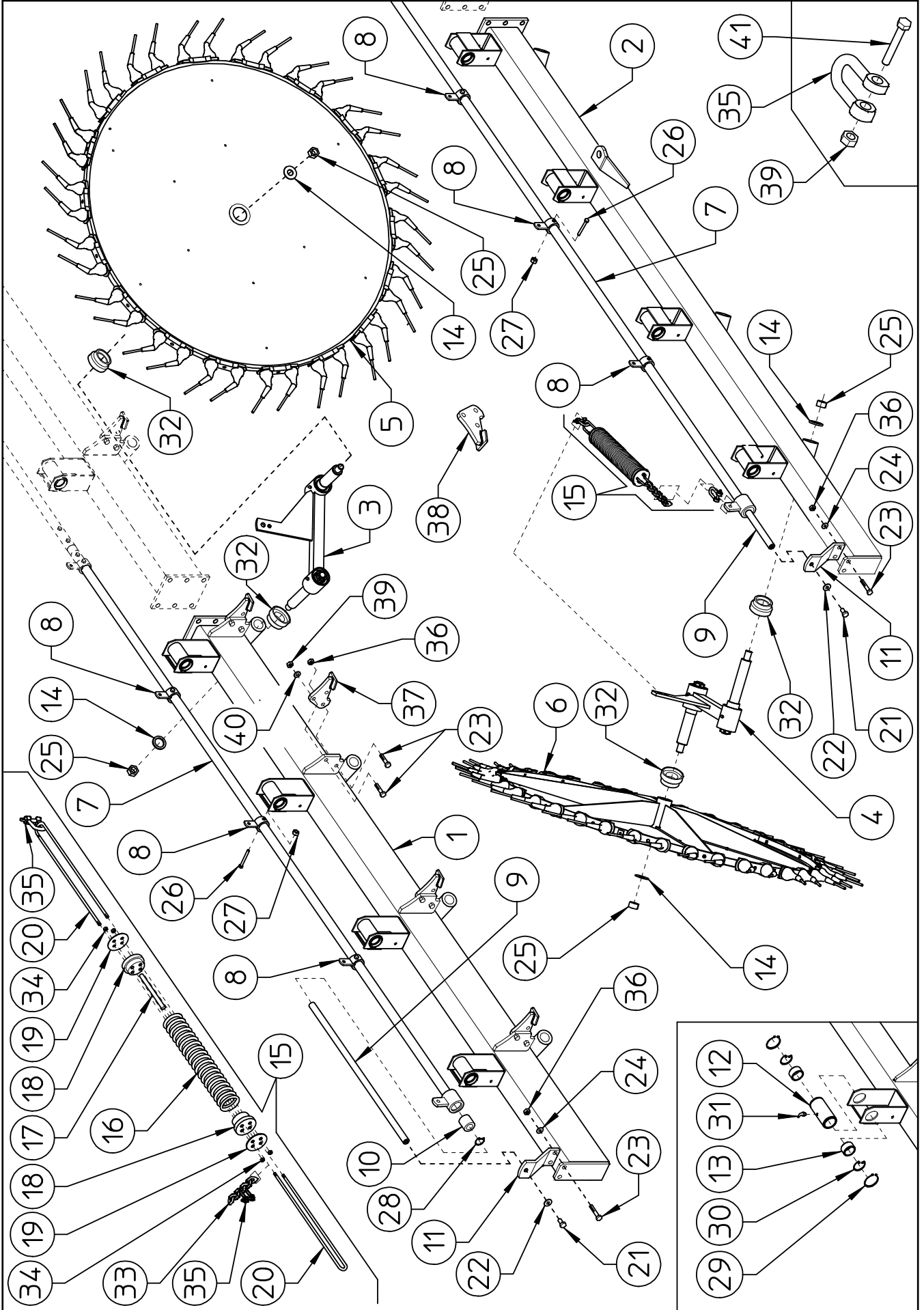

TABLE PART NO 920.335				
ITEM	PART NO	Q.ty	DESCRIPTION	Note
1	250.023	1	RH SECTION	With block
2	250.024	1	LH SECTION	With block
3	230.540	9	RH ARM, ASSY	
4	230.541	8	LH ARM, ASSY	
5	230.543	9	RH FINGER WHEEL, ASSY	
6	230.544	8	LH FINGER WHEEL, ASSY	
7	230.587	2	PIPE (L.3040-119,68")	
8	230.592	6	BUSH	
9	230.590	2	ROD ø20	
10	230.591	2	BUSH ø35	
11	230.831	2	FRONT SUPPORT	
12	220.343	8	BUSH	
13	220.342	16	NYLON BUSH	
14	200.165	34	WASHER ø23-50x4	
15	230.738	17	SPRING, ASSY	
16	230.739	17	SPRING	
17	230.743	17	RUBBER SPRING	
18	230.742	34	NYLON BUSH	
19	230.741	34	PLATE	
20	230.740	34	TIE ROD	
21	600.770	2	SCREW M12x20 DIN 933	
22	600.018	2	SPRING WASHER ø13 DIN 125A	
23	600.641	38	SCREW M10x35 DIN 933	
24	600.322	4	WASHER ø10.5 DIN 125A	
25	600.079	34	NUT M22 DIN 980	
26	610.525	6	SCREW M8x60 DIN 931	
27	600.076	6	NUT M8 DIN 980	
28	630.453	2	SNAP RING I35 DIN 472	
29	610.833	16	SNAP RING E50 DIN 471	
30	610.898	16	RING SB 44	
31	600.968	8	GREASE NIPPLE M6-45°	
32	230.550	34	PROTECTION	
33	200.749	17	CHAINE (L.196-7,72")	
34	600.472	68	NUT M6 DIN 980	
35	630.927	34	"D" SHACKLE	
36	600.029	21	NUT M10 DIN 980	
37	250.010	9	RH LOCK	
38	250.011	8	LH LOCK	
39	600.010	51	NUT M10 DIN 934	
40	600.024	17	SPRING WASHER ø10.5 SIMILAR TO 127B	
41	600.404	34	SCREW M10x50 DIN 931	

TABLE PART NO 920.298

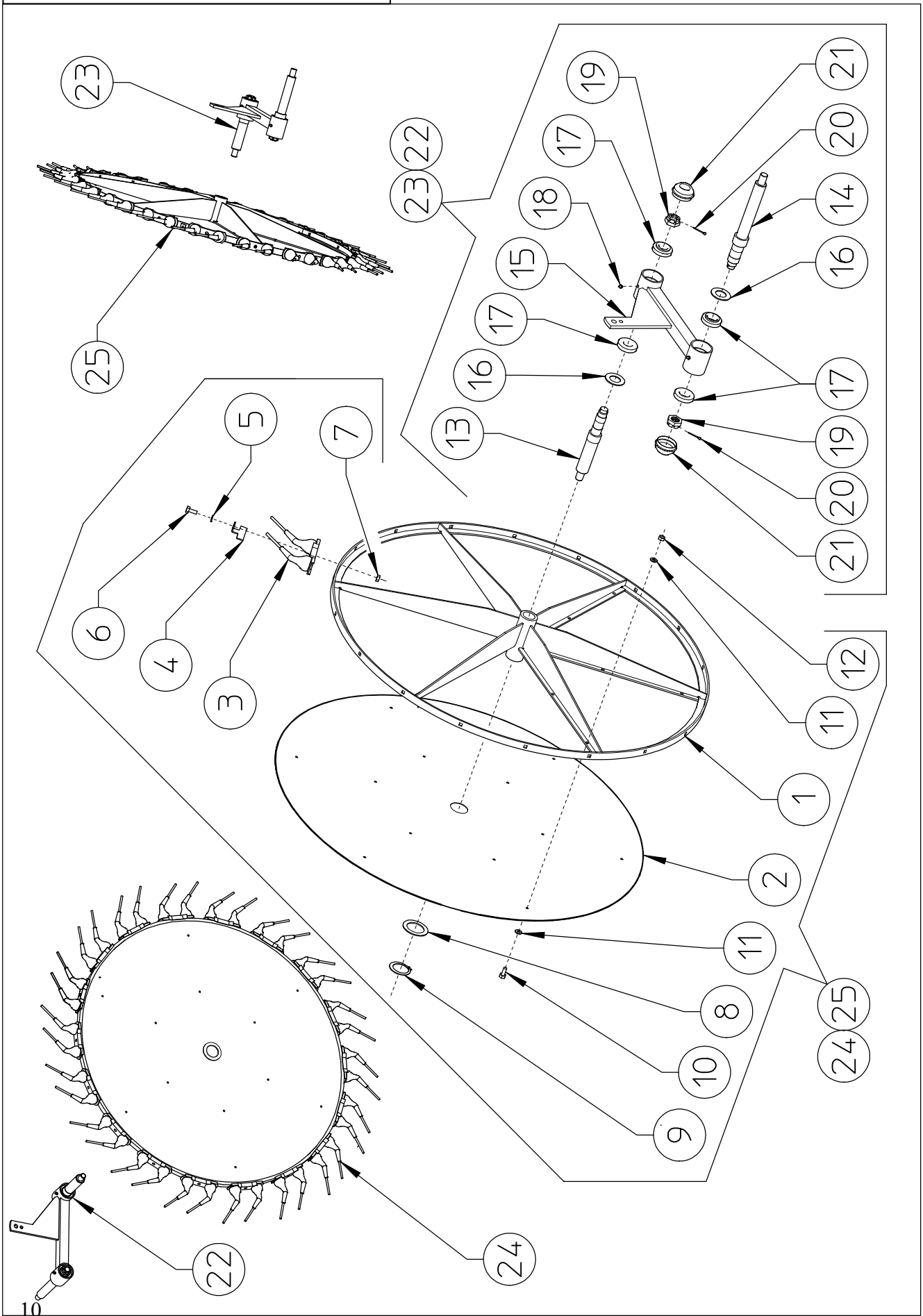

TABLE PART NO 920.298				
ITEM	PART NO	Q.ty	DESCRIPTION	NOTE
1	230.545	17	RIM	
2	230.508	17	FLANGE	
3	230.466	306	TINE	
4	230.548	102	LOCK	
5	600.322	306	WASHER ø10.5 DIN 433	
6	600.006	306	SCREW M10x25 DIN 933	
7	600.029	306	NUT M10 DIN 980	
8	230.549	17	WASHER ø80-56x3	
9	600.908	17	SNAP RING E55 DIN 471	
10	630.003	204	SCREW M6x20 DIN 933	
11	600.135	408	WASHER ø6,6 UNI 6593	
12	600.472	204	NUT M6 DIN 980	
13	230.547	17	PIN ø35 L.275-10,83"	
14	230.546	17	PIN ø35 L.310-12,2"	
15	230.542	17	ARM	
16	610.960	34	DUST COVER	
17	610.935	68	BEARING 32007X	
18	600.124	34	GREASE NIPPLE M6	
19	600.288	34	LOCK NUT M27x1,5	
20	600.291	34	SPLIT PIN ø4x40 DIN 94	
21	600.290	34	CAP	
22	230.540	9	RH ARM, ASSY	
23	230.541	8	LH ARM, ASSY	
24	230.543	9	RH FINGER WHEEL, ASSY	
25	230.544	8	LH FINGER WHEEL, ASSY	

TABLE PART NO 920.299/a

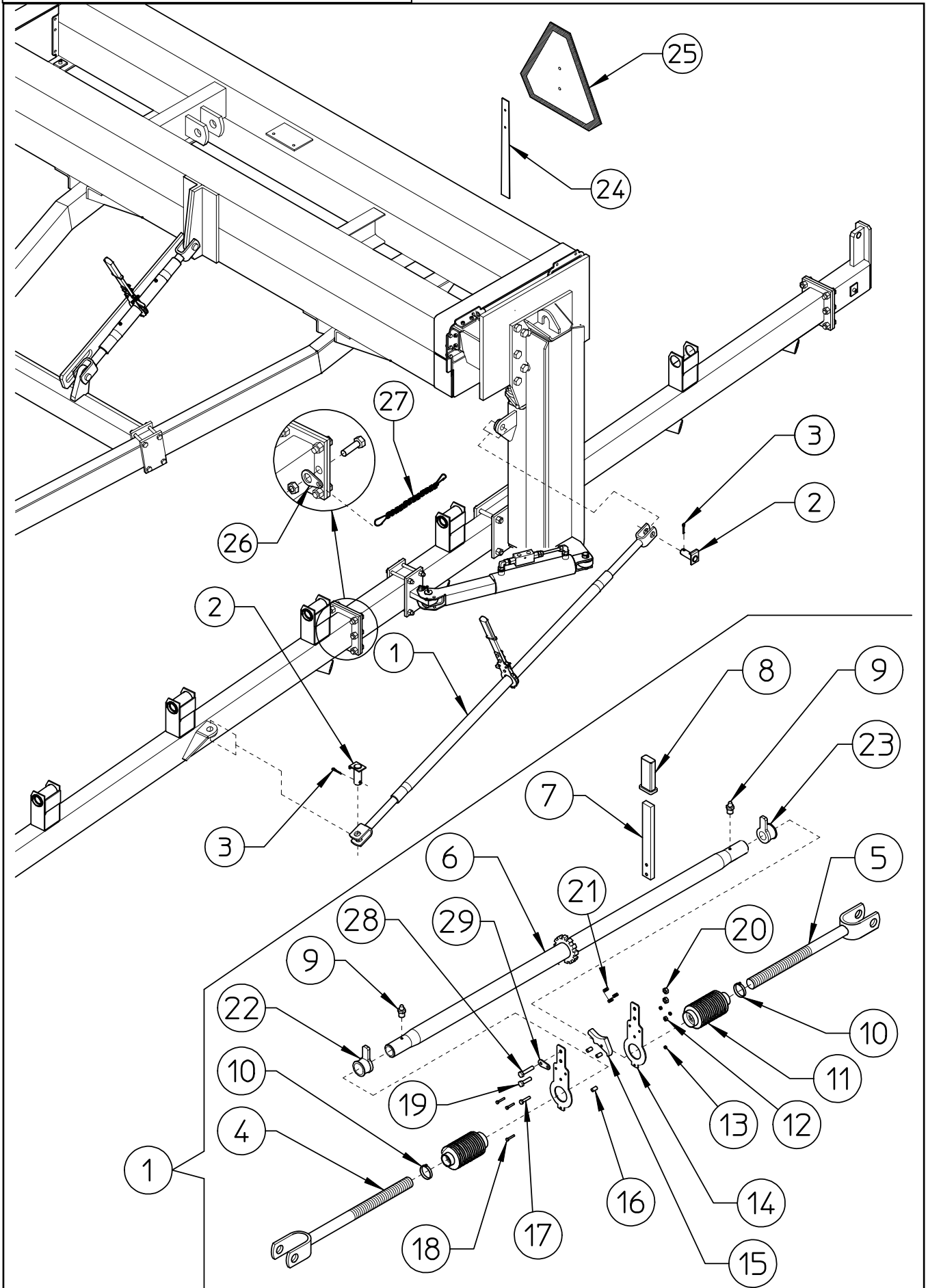

TABLE PART NO 920.299/a				
ITEM	PART NO	Q.ty	DESCRIPTION	NOTE
1	230.609	2	RATCHET LINK	
2	230.368	4	PIN ø25	
3	600.038	4	SPLIT PIN ø6x35 DIN 94	
4	230.610	2	RH TIEROD	
5	230.611	2	LH TIEROD	
6	220.182	2	TIE ROD	
7	220.213	2	LEVER	
8	610.811	2	HANDLE	
9	600.124	4	GREASE NIPPLE M6	
10	610.507	4	CLAMP ø25-40x9	
11	220.192	4	RUBBER PROTECTION	
12	600.472	2	NUT M6 DIN 980	
13	610.718	6	NUT M4 DIN 982	
14	220.205	4	SUPPORT	
15	220.070	2	HOOK	
16	220.215	6	SPACER	
17	600.202	2	SCREW M6x25 DIN 933	
18	610.717	6	SCREW M4x25 DIN 933	
19	600.702	2	SCREW M8x25 DIN 933	
20	600.076	4	NUT M8 DIN 980	
21	220.073	2	SPRING	
22	220.201	2	LOCKING BUSH RH	
23	220.202	2	LOCKING BUSH LH	
24	220.413	1	SPADE	
25	220.414	1	SMV EMBLEME WITH ACCESS.	
26	250.009	2	SUPPORT	
27	630.929	2	CHAINE	
28	600.757	2	SCREW M8x30 DIN 933	
29	250.026	2	SUPPORT	

TABLE PART NO 920.300/a

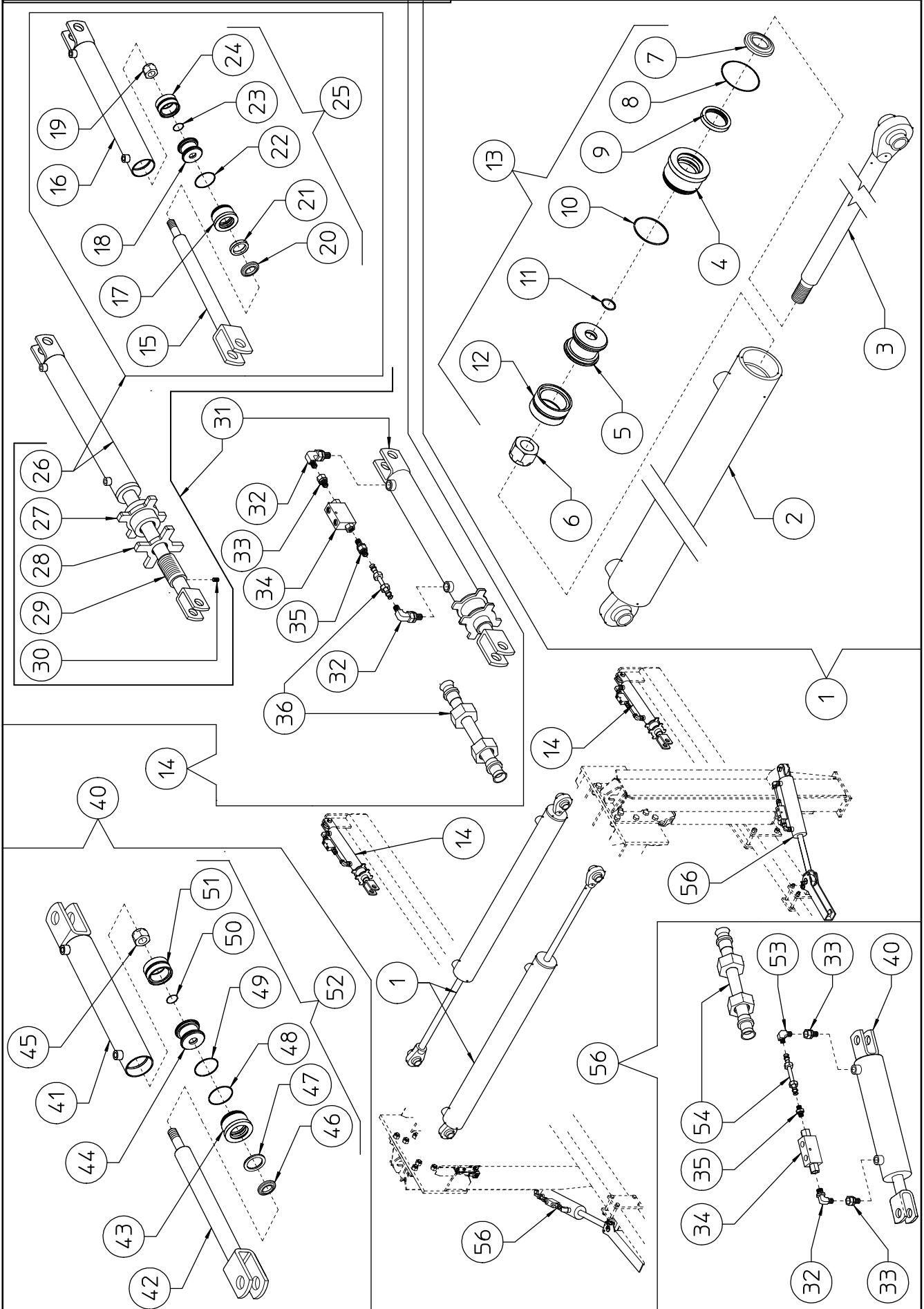

TABLE PART NO 920.300/a

ITEM	PART NO	Q.ty	DESCRIPTION	NOTE
1	230.559	2	CYLINDER ø90-40x1225	
2	230.631	2	CYLINDER BARREL ø90	(one for cylinder)
3	230.632	2	ROD ø40	(one for cylinder)
4	230.634	2	CYLINDER HEAD ø90-40	(one for cylinder)
5	230.635	2	PISTON ø90	(one for cylinder)
6	610.005	2	NUT M27x2 DIN 982	(one for cylinder)
7	610.600	2	GASKET WRM 157188 or equivalent (rod ø40)	(one for cylinder)
8	630.681	2	OR GASKET ø82,22x2,62	(one for cylinder)
9	610.599	2	GASKET 196157 or equivalent (rod ø40)	(one for cylinder)
10	630.680	2	GASKET GDS 620 or OR GASKET ø79,77x5,34	(one for cylinder)
11	610.009	2	OR GASKET ø26,58x3,53	(one for cylinder)
12	630.492	2	GASKET DBM 354275 or equivalent (ø90)	(one for cylinder)
13	630.491	2	SET OF GASKET	(one for cylinder)
14	230.794	2	CYLINDER ø50-30 WITH BUSHING AND VALVE	
15	210.221	2	ROD ø30	(one for cylinder)
16	210.222	2	CYLINDER BARREL ø50	(one for cylinder)
17	220.524	2	CYLINDER HEAD ø50-30	(one for cylinder)
18	200.304	2	PISTON ø50	(one for cylinder)
19	600.642	2	NUT M18x1,5 DIN 982	(one for cylinder)
20	600.645	2	GASKET WRM 118149 or equivalent (rod ø30)	(one for cylinder)
21	610.031	2	GASKET B157118/1 or equivalent (rod ø30)	(one for cylinder)
22	610.090	2	OR GASKET ø42,86x3,53	(one for cylinder)
23	600.646	2	OR GASKET ø20,29x2,62	(one for cylinder)
24	600.648	2	GASKET DBM 196133 or equivalent (ø50)	(one for cylinder)
25	620.022	2	SET OF GASKET ø50-30	(one for cylinder)
26	210.816	2	CYLINDER ø50-30 WITHOUT BUSHING	
27	230.583	2	BUSH M40x1,5	(one for cylinder)
28	230.582	2	LOCK M40x1,5	(one for cylinder)
29	230.581	2	SCREW M40x1,5	(one for cylinder)
30	600.583	2	SCREW M6x10 DIN 914	(one for cylinder)
31	230.584	2	CYLINDER ø50-30 WITH BUSHING	
32	630.639	6	FITTING 90° 3/8" - 3/4" 16 UNF JIC 37°	(2-1 for cylinder)
33	630.633	6	FITTING 3/8" - 3/4" 16 UNF JIC 37°	(1-2 for cylinder)
34	600.799	4	LOCK VALVE 3/8"	(one for cylinder)
35	630.638	4	FITTING 3/8" - 3/4" 16 UNF JIC 37°	(one for cylinder)
36	230.795	2	TUBE ø12 WITH NUT AND BUSH	(one for cylinder)
37 - DELETED				
38 - DELETED				
39 - DELETED				
40	210.570	2	CYLINDER ø70-30x210	
41	210.341	2	CYLINDER BARREL ø70	(one for cylinder)
42	210.568	2	ROD ø30	(one for cylinder)
43	210.569	2	CYLINDER HEAD ø70-30	(one for cylinder)
44	210.227	2	PISTON ø70	(one for cylinder)
45	600.879	2	NUT M24x2 DIN 982	(one for cylinder)
46	600.645	2	GASKET WRM 118149 or equivalent (rod ø30)	(one for cylinder)
47	610.031	2	GASKET B157118/1 or equivalent (rod ø30)	(one for cylinder)
48	620.668	2	OR GASKET ø69,52x2,62	(one for cylinder)
49	610.923	2	OR GASKET ø63,5x3,53+BK	(one for cylinder)
50	620.669	2	OR GASKET ø18,72x2,62	(one for cylinder)
51	600.984	2	GASKET DBM 275196 or equivalent (ø70)	(one for cylinder)
52	610.340	2	SET OF GASKET ø70-30	(one for cylinder)
53	630.634	2	FITTING 90° 3/4" 16 UNF JIC 37°	(two for cylinder)
54	230.792	2	TUBE ø12 WITH NUT AND BUSH	(one for cylinder)
55 - DELETED				
56	230.793	2	CYLINDER ø70-30 WITH VALVE	

TABLE PART NO 920.332/a

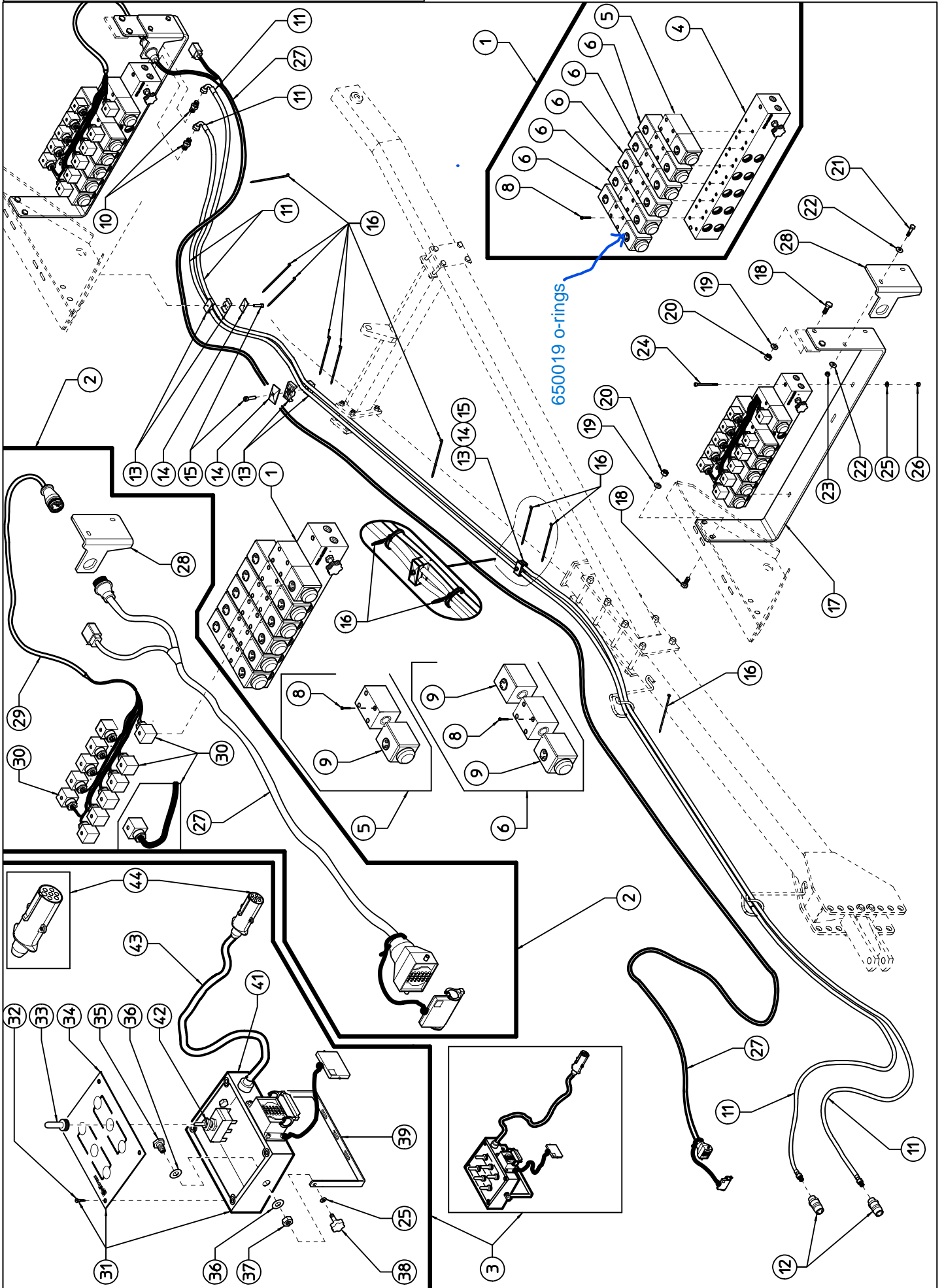

TABLE PART NO 920.332/a

TABLE PART NO 920.332/a

ITEM	PART NO	Q.ty	DESCRIPTION	NOTE
1	230.980	1	VALVE ASSY	
2	630.592	1	HARNESS	
3	630.593	1	CONTROL BOARD	
4	630.591	1	BASE WITH 6 CONNECTIONS	
5	630.506	1	SOLENOID VALVE (12V DC)	
6	630.505	5	SOLENOID VALVE (12V DC)	
7			DELETED	
8	630.511	24	SCREW M5x30 DIN 912	
9	630.510	11	COIL	
10	630.674	2	FITTING 1/2" MALE 3/4" JIC 37° MALE	
11	630.654	2	HOSE 3/8" L.7500-295,30" - 1/2 NPT MALE - 3/4 JIC 37° FEMALE 90°	
12	620.329	2	RAPID COUPLING 1/2" NPT	
13	610.162	6	COLLAR ø18	
14	610.164	3	CLAMP	
15	610.165	3	SCREW M8x35 DIN 933	
16	620.039	9	CLAMP 4,5x300	
17	230.563	1	SUPPORT	
18	600.148	4	SCREW M10x30 DIN 933	
19	600.322	4	WASHER ø10,5 DIN 125A	
20	600.029	4	NUT M10 DIN 980	
21	600.202	2	SCREW M6x25 DIN 933	
22	600.135	4	WASHER ø6,6/18 UNI 6593	
23	600.472	2	NUT M6 DIN 980	
24	630.484	2	SCREW M5x80 DIN 912	
25	630.490	4	WASHER ø5,3/15 UNI 6593	
26	620.367	2	NUT M5 DIN 980	
27	640.062	1	CABLE L.10000 - 33' WITH ELECTRICAL PLUG	
28	250.221	1	SUPPORT	
29	640.061	1	EMPTY CABLE SOLENOID VALVE BOX	
30	630.512	11	CONNECTOR WITH CABLE	
31	630.684	1	EMPTY CONTROL BOX	
32	630.520	4	SCREW	
33	630.517	6	PROTECTION	
34	630.519	1	PANEL	
35	230.615	2	PIN M12/ø9/M5	
36	600.089	4	WASHER ø13 DIN 125A	
37	600.132	2	NUT M12 DIN 936	
38	630.486	2	HANDLE ø23-M5x20	
39	230.616	1	SUPPORT	
40			DELETED	
41	630.686	1	BOX LESS COVER	
42	630.518	6	SWITCH	
43	630.687	1	CABLE L.2000 - 78,75" WITH ELECTRICAL PLUG 44	
44	630.688	1	ELECTRICAL PLUG	

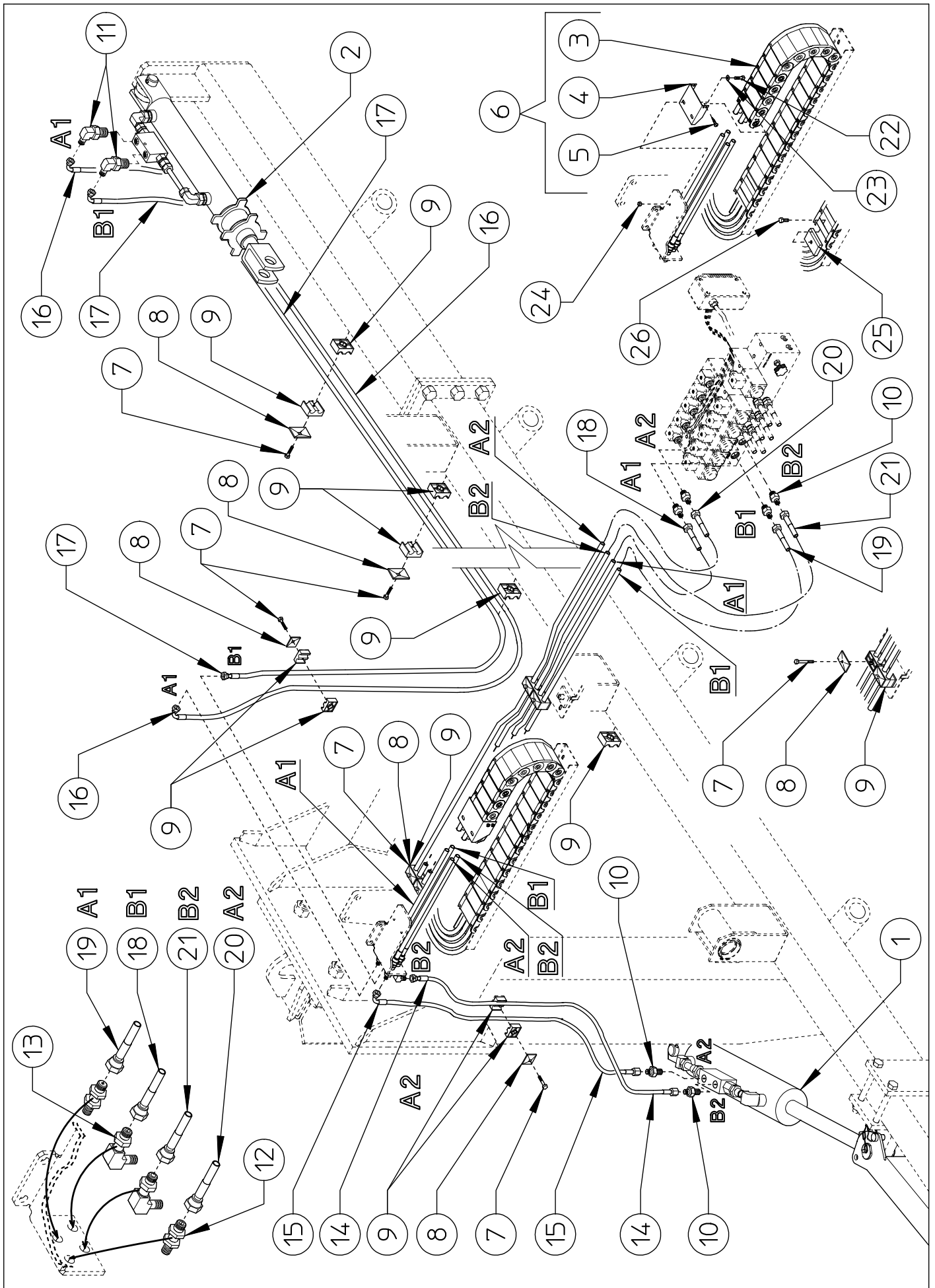

TABLE PART NO 920.302				
ITEM	PART NO	Q.ty	DESCRIPTION	NOTE
1	230.793	1	CYLINDER ø70-30 WITH ACCESORIES AND VALVE	
2	230.794	1	CYLINDER ø50-30 WITH ACCESORIES AND VALVE	
3	230.594	1	CHAINE SR 305	
4	230.597	2	SUPPORT	
5	630.454	8	SCREW ø3,9 (7P) DIN 7982B	
6	230.596	1	CHAINE, ASSY	
7	610.803	9	SCREW M6x35 DIN 931	
8	610.802	9	CLAMP	
9	630.078	19	DOUBLE COLLAR ø12	
10	630.675	6	FITTING 3/8" GAS-1/2 JIC 37°	
11	630.678	2	FITTING 90° 3/8" GAS -1/2" JIC 37°	
12	630.676	2	FITTING 1/2 JIC 37°	
13	630.677	2	FITTING 90° 1/2 JIC 37°	
14	630.655	1	HOSE 1/4" L.1140 - 44,88" FEMALE 1/2 JIC 37°	
15	630.656	1	HOSE 1/4" L.1160 - 45,67" FEMALE 1/2 JIC 37°-FEMALE 90° 1/2 JIC 37°	
16	630.665	1	HOSE 1/4" L.4320 - 170" FEMALE 90° 1/2 JIC 37°	
17	630.666	1	HOSE 1/4" L.4220-166,14" FEMALE 1/2 JIC 37°-FEMALE 90° 1/2 JIC 37°	
18	630.667	1	HOSE 1/4" L.3080 - 121,26" FEMALE 1/2 JIC 37°	
19	630.668	1	HOSE 1/4" L.3060 - 120,47" FEMALE 1/2 JIC 37°	
20	630.659	1	HOSE 1/4" L.3190 - 125,59" FEMALE 1/2 JIC 37°	
21	630.660	1	HOSE 1/4" L.3170 - 124,8 " FEMALE 1/2 JIC 37°	
22	630.003	4	SCREW M6x20 DIN 933	
23	600.135	4	WASHER ø6,6-18 UNI 6593	
24	600.472	4	NUT M6 DIN 980	
25	230.617	1	LOCK	
26	600.668	1	SCREW M6x12 DIN 933	

TABLE PART NO 920.331

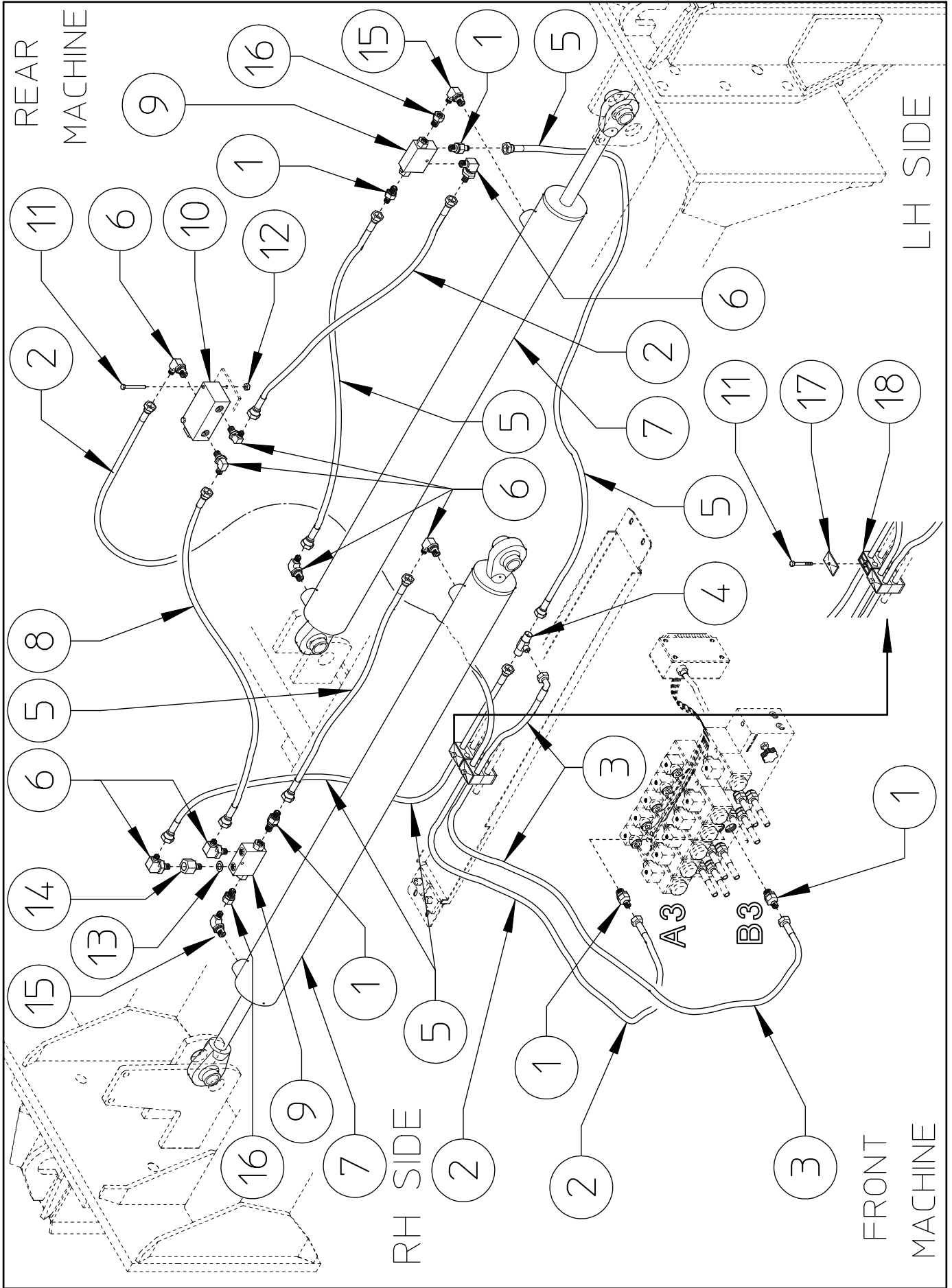

TABLE PART NO 920.331				
ITEM	PART NO	Q.ty	DESCRIPTION	NOTE
1	630.675	5	FITTING 3/8" GAS-1/2 JIC 37°	
2	630.669	2	HOSE 1/4" L.900 - 35,43" FEMALE 1/2 JIC 37°	
3	630.670	1	HOSE 1/4" L.700 - 27,56" FEMALE 1/2 JIC 37° - FEMALE 90° 1/2 JIC 37°	
4	630.679	1	"T" FITTING 1/2 JIC 37° MALE	
5	630.671	4	HOSE 1/4" L.1100 - 43,31" FEMALE 1/2 JIC 37°	
6	630.678	8	FITTING 90° 3/8" GAS-1/2 JIC 37°	
7	230.559	2	CILYNDER ø90-40x1225	
8	630.912	1	HOSE 1/4" L.1040 - 40,94" FEMALE 1/2 JIC 37°	
9	600.799	2	LOCK VALVE 3/8"	
10	600.974	1	FLOW DIVIDER 3/8"	
11	600.970	4	SCREW M6x60 DIN 931	
12	600.472	2	NUT M6 DIN 980	
13	620.452	1	WASHER 3/8"	
14	630.924	1	FITTING MALE 3/8" FEMALE 3/8"	
15	630.639	2	FITTING 90° 3/8" GAS-3/4-16 UNF	
16	630.633	2	FITTING 3/8" GAS-3/4-16 UNF	
17	610.802	2	CLAMP	
18	630.078	8	DOUBLE COLLAR ø12	

TABLE PART NO 920.304

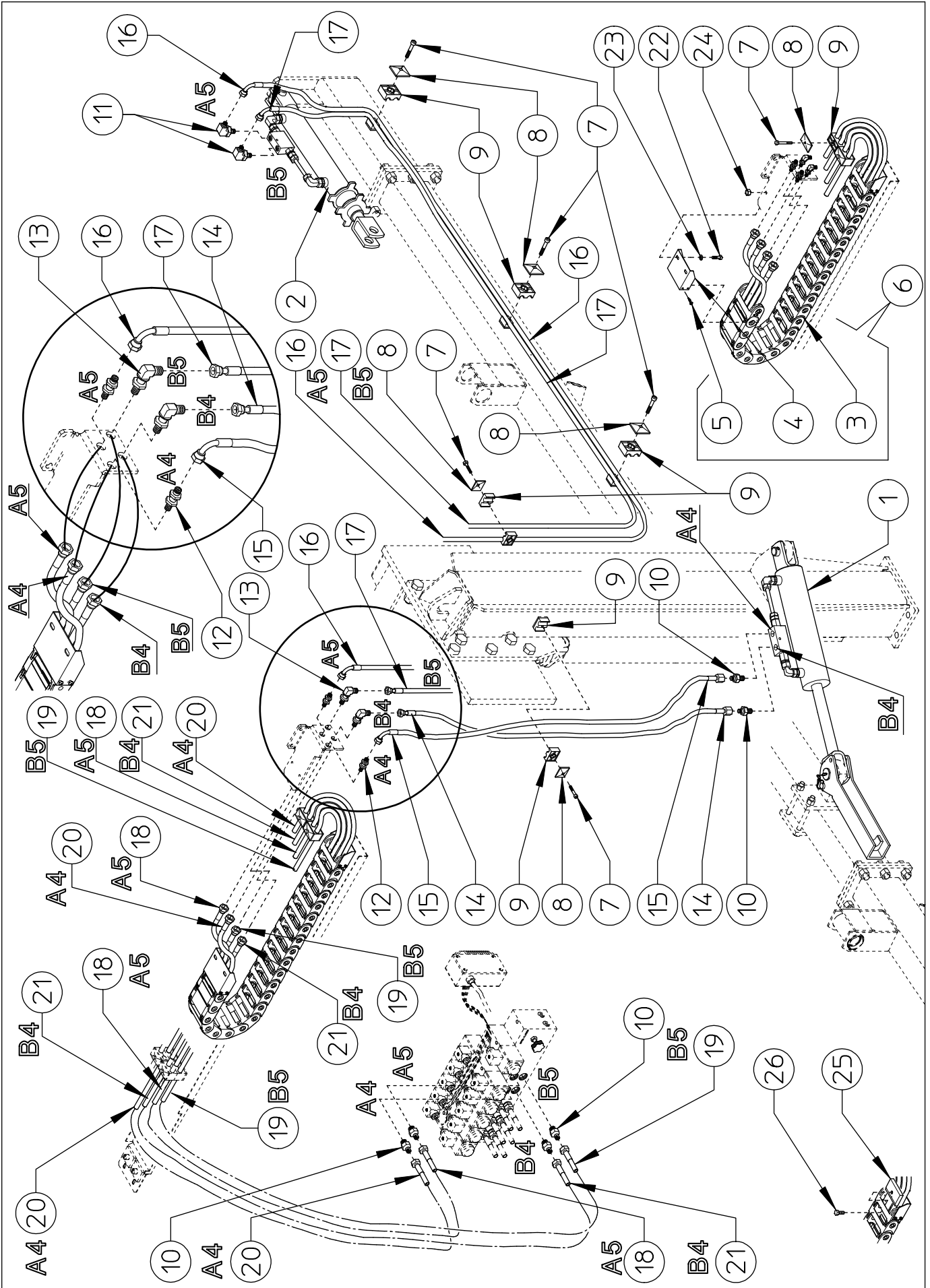
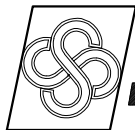

TABLE PART NO 920.304

ITEM	PART NO	Q.ty	DESCRIPTION	NOTE
1	230.793	1	CYLINDER ø70-30 WITH ACCESORIES AND VALVE	
2	230.794	1	CYLINDER ø50-30 WITH ACCESORIES AND VALVE	
3	230.594	1	CHAINE SR 305	
4	230.597	2	SUPPORT	
5	630.454	8	SCREW ø3,9 (7P) DIN 7982B	
6	230.596	1	CHAINE, ASSY	
7	610.803	7	SCREW M6x35 DIN 931	
8	610.802	7	CLAMP	
9	630.078	14	DOUBLE COLLAR ø12	
10	630.675	6	FITTING 3/8" GAS-1/2 JIC 37°	
11	630.678	2	FITTING 90° 3/8" GAS -1/2" JIC 37°	
12	630.676	2	FITTING 1/2 JIC 37°	
13	630.677	2	FITTING 90° 1/2 JIC 37°	
14	630.655	1	HOSE 1/4" L.1140 - 44,88" FEMALE 1/2 JIC 37°	
15	630.656	1	HOSE 1/4" L.1160 - 45,67" FEMALE 1/2 JIC 37°-FEMALE 90° 1/2 JIC 37°	
16	630.661	1	HOSE 1/4" L.3600 - 141,7" FEMALE 90° 1/2 JIC 37°	
17	630.662	1	HOSE 1/4" L.3520-138,58" FEMALE 1/2 JIC 37°-FEMALE 90° 1/2 JIC 37°	
18	630.663	1	HOSE 1/4" L.3810 - 150" FEMALE 1/2 JIC 37°	
19	630.664	1	HOSE 1/4" L.3790 - 149,22" FEMALE 1/2 JIC 37°	
20	630.657	1	HOSE 1/4" L.3940 - 155,12" FEMALE 1/2 JIC 37°	
21	630.658	1	HOSE 1/4" L.3910 - 153,94 " FEMALE 1/2 JIC 37°	
22	630.003	4	SCREW M6x20 DIN 933	
23	600.135	4	WASHER ø6,6-18 UNI 6593	
24	600.472	4	NUT M6 DIN 980	
25	230.617	1	LOCK	
26	600.668	1	SCREW M6x12 DIN 933	



AGRICULTURAL MACHINERY
sitrex® SpA .

Zona Industriale-Viale Grecia, 8
06018 TRESTINA-(Perugia)-ITALY
Tel. +39.075.8540021-Telefax +39.075.8540523
e-mail: sitrex@sitrex.it www.sitrex.com

